

## Lifting Point threaded VWBG 6(7,5)t with special thread

Artikel-Nr:

8600150



Special thread versions are available. When ordering, indicate the required thread diameter and length. Available thread sizes. M33 (also as fine thread) 1 3/8" Thread length: 33-300 Special load rings are non stock items and production is subject to customer demand. Bear the respective delivery periods in mind. Suitable for all loads which swivel and tilt. Can be loaded in all directions with a 4 : 1 design factor. Swiveling under full load is permissible provided the inclination angle is not perpendicular to the screw - in direction. Not suitable for permanent swiveling under full load. Suitable for through bores. Easy assembly due to the single threaded tapping. High tensile, inspected suspension ring according to EN 1677 or DIN 5688-8. The surface is pink painted. Choose the attachment points in such a way that the introduced forces are accommodated by the work piece without being deformed. Make sure the bolting surface is plain. Ensure an appropriate bore depth to facilitate an optimal sitting of the engaging surface. Work piece material, at least 1.0037 (St 37). The BG recommends the following min. thread lengths: 1 x M for Steel 1,25 x M for Cast 2 x M for Aluminium For light metals, nonferrous heavy metals and grey cast iron, the thread type allocation must be done in such a way that, the WLL of the thread type fulfils the requirements of the respective work piece. Owing to the presence of the ball bearing, in case of a single transportation procedure, fastening with a flat wrench according to DIN 895 or DIN 894 without using an extension is enough. Without a washer, the seat - engaging surface of the VWBG (D) must completely and evenly lie onto the surface of the work piece. Is the VWBG to be permanently loaded, it must be tightened with a torque of 350 Nm. When impact loaded or operated in environments with skewing and vibrations, unintentional loosening can happen, especially if through bolts with nuts are used. Securing possibilities: Use of a liquid thread securing medium eg. Loctite ( follow the manufacturer's recommendations) or positive bolt securing for example using a castellated nut with a split pin, counter nut etc.

## Lifting Point threaded VWBG 6(7,5)t with special thread

Artikel-Nr: 8600150

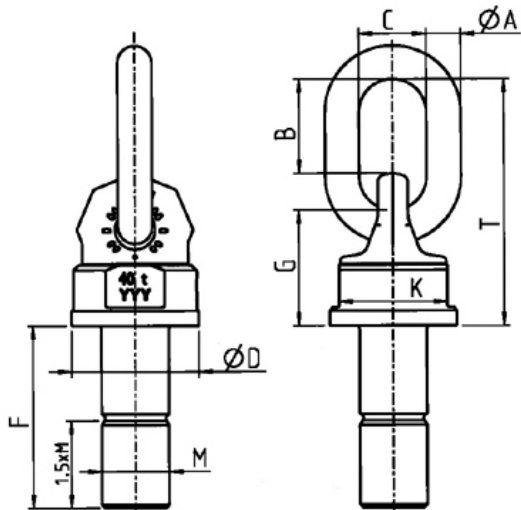

Nominal WLL	6000 kg	13200 lbs
T	208 mm	8-3/16"
A	23 mm	29/32"
B	86 mm	3-3/8"
C	50 mm	1-31/32"
D	90 mm	3-17/32"
E	80 mm	3-1/8"
F	33-300 mm	33-300
G	94 mm	3-11/16"
M	M33 mm	M33