

# QUAD HOOK



The Quad Hook is used to safely and efficiently move large coils of steel in the vertical bore position.

Serious injury has occurred when using a conventional bore T-hook and other non-standard tools. The Quad Hook is a solution which not only provides extra safety for operators but minimises the likelihood coil damage from unravelling. With an innovative cradle support system the Quad Hook is designed for ease-of-use and provides extra peace of mind to employers concerned about safety.

- Unique patented design solution to a common safety problem
- Four pivoting arms provide an evenly distributed cradled support for the coils
- Quick and easy engage and disengage of the arms significantly reduces potential for coil damage
- Handling grips designed for manoeuvrability
- Remote uncoupling to allow for safe lifting to and from high storage
- Wide and narrow versions available to suit coils being lifted
- Stand specifically designed for safe hook storage
- 100% Australian Made Quality

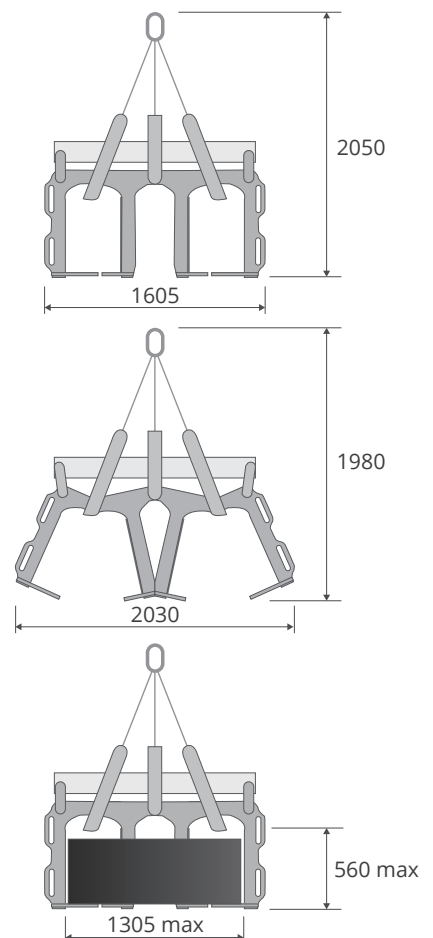



Quad Hook

For a customised quote please enter details below

### YOUR DETAILS

Name

Company name

PH:

E-mail

### JOB DETAILS

Coil OD

mm Min

mm Max

Coil width

mm

Coil weight

kg

Crane size

tonne

### COMMENTS / REQUESTS

Email completed form to: [engineering@rud.com.au](mailto:engineering@rud.com.au)