

Complies with the machinery directives 2006/42/EC

**4** better lifting



**NB:** Please ensure that the safety instructions have been fully read and understood before initial use of the VRS bolt-on lifting point. Failure to do so may result in serious injuries and/or material damage and eliminates manufacturers warranty.

## User Instructions - Part 1

### Safety instructions

This safety instruction/declaration of the manufacturer must be kept on file for the lifetime of the product.

**ATTENTION:** Please inspect all lifting points prior to use. Damage, incorrect assembly or improper use may result in serious injuries and/or material damage.

### EC-Declaration of the manufacturer

According to the Machinery Directive 2006/42/EC, annex II B and amendments.

We hereby declare that the design and construction of the equipment detailed within this document, adheres to the appropriate level of health and safety of the corresponding EC regulation.

Any un-authorized modification and/or any incorrect use of the equipment not adhered to within these user instructions waives this declaration invalid.

The equipment must be regularly tested and inspected as per BGR 500. Failure to carry out the recommended maintenance and testing waives this declaration invalid.

### Designation of the equipment:

Type: **VRS (-F) bolt-on lifting point**

Manufacturer's mark:

Drawings (iges, dxf and step), product information and other support material can be downloaded from [www.rud.com.au](http://www.rud.com.au).

**EC-Declaration of conformity**

According to the EC-Machinery Directive 2006/42/EC, annex II A and amendments

Manufacturer: **RUD Ketten Rieger & Dietz GmbH u. Co. KG**  
Friedensinsel  
73432 Aalen

We hereby declare that the equipment sold by us because of its design and construction, as mentioned below, corresponds to the appropriate, basic requirements of safety and health of the corresponding EC-Machinery Directive 2006/42/EC as well as to the below mentioned harmonized and national norms as well as technical specifications. In case of any modification of the equipment, not being agreed upon with us, this declaration becomes invalid.

Product name: STARPOINT eye bolt  
VRS

The following harmonized norms were applied:

|                 |                  |
|-----------------|------------------|
| <u>EN 12100</u> | <u>EN 1677-1</u> |
| _____           | _____            |
| _____           | _____            |

The following national norms and technical specifications were applied:

|                        |       |
|------------------------|-------|
| <u>BGR 500, KAP2.8</u> | _____ |
| _____                  | _____ |
| _____                  | _____ |

Authorized person for the configuration of the declaration documents:  
Reinhard Smetz, RUD Ketten, 73432 Aalen

Aalen, 03.01.2013

Dr. Ing. Rolf Storz, (Proturist/CMB)

Name, function and signature of the responsible person

## User Instructions - Part 2

1. Reference should be made to relevant standards and other statutory regulations. Inspections should be carried out by competent persons only.

2. Before installing and every use, visually inspect RUD lifting points, with particular attention to any evidence of corrosion, wear and weld cracks and deformations. Please ensure compatibility of bolt thread and tapped hole.

3. The material construction to which the lifting point will be attached, should be of adequate strength to withstand forces during lifting without deformation. RUD, with reference to the German testing authority BG, recommends the following minimum for bolt lengths:

- 1.5 x M in steel (minimum quality S235JR [1.0037]) ≈ AS3678 GR250.
- 1.5 x M in cast iron (for example GG 25)
- 2 x M in aluminium alloys
- 2.5 x M in aluminium-magnesium alloys
- ( M = diameter of RUD lifting point bolt, e.g. M 20 )

When lifting light metals, nonferrous heavy metals and gray cast iron, the thread has to be chosen in such a way that the working load limit of the thread corresponds to the requirements of the respective base material.

4. The lifting points must be positioned on the load in such a way that movement is avoided during lifting.

- For single leg lifts, the lifting point should be vertically above the centre of gravity of the load.
- For two leg lifts, the lifting points must be equidistant to/above the centre of gravity of the load.
- For three and four leg lifts, the lifting points should be arranged symmetrically around the centre of gravity in the same plane if possible.

5. Load Symmetry: The working load limit of individual RUD lifting points are calculated using the following formula and are based on symmetrical loading:

|  |  |
|--|--|
| $W_{LL} = \frac{G}{n \times \cos \beta}$ | WLL = required of lifting point/individual leg (kg)<br>G = load weight (kg)<br>n = number of load bearing legs<br>β = angle of inclination of the individual leg |
|--|--|

**NOTE: For WLL Calculations**

- β angle is taken from the vertical plane.
- Included angle is the angle between the sling legs.



6. Safety: When lifting points are used in a multileg assembly, care should be taken to calculate the WLL (Working Load Limit) due to the deration caused by forces acting in multiple directions. The reduction in WLL (Working Load Limit) for multileg assemblies should be checked with relevant Standards e.g. AS 3775-2004 - Chain Slings-Gr t (8)

The lifting points should be mounted in such a way that they may easily be accessed for inspection and assembly/disassembly of the sling.

7. A plane bolting surface must be guaranteed to ensure correct mating of the lift component.

8. For fitting without tools and for inspection of the compatibility of bolt thread and tapped hole the STARPOINT can be delivered with a tempered key (type: VRS-F). Simply engage the Hexagon socket bolt with the star profile key and tighten by hand. Disengage the key before attaching the lifting mean.

For a long term application the VRS should be tightened to torque according to table below (+/- 10%).

| Type metric | Type Inch       | Torque  | Socket wrench |
|-------------|-----------------|---------|---------------|
| VRS-M8      | -               | 10 Nm   | 7997749       |
| VRS-M10     | VRS-3/8"-16UNC  | 15 Nm   | 7997749       |
| VRS-M12     | VRS-1/2"-13UNC  | 25 Nm   | 7997750       |
| VRS-M16     | VRS-5/8"-11UNC  | 60 Nm   | 7997751       |
| VRS-M20     | VRS-3/4"-10UNC  | 115 Nm  | 7997752       |
| -           | VRS-7/8"-9UNC   | 125 Nm  | -             |
| VRS-M24     | VRS-1"-8UNC     | 190 Nm  | 7997753       |
| VRS-M30     | VRS-1 1/4"-7UNC | 330 Nm  | -             |
| VRS-M36     | VRS-1 1/2"-6UNC | 590 Nm  | -             |
| VRS-M42     | VRS-1 3/4"-5UNC | 925 Nm  | -             |
| VRS-M48     | VRS-2"-4,5UNC   | 1400 Nm | -             |

9. To prevent unintended dismounting through shock loading, rotation or vibration, thread locking fluid such as Loctite (depending on the application, please refer to the manufacturer's instruction) should be used to secure the eyebolt.

10. The STARPOINT has to be adjustable through 360° when fitted and with key disengaged. Adjust to direction of pull before attaching of the lifting means.

**Attention: STARPOINT's are not suitable for rotation under load!**



11. All fittings connected to the eyebolt should be free moving. When connecting and disconnecting the lifting means (wire ropes, chain slings, round slings) pinches and impacts should be avoided. Damage to lifting components caused by sharp corners should also be avoided.

12. Effects of temperature:

Due to the DIN/EN bolts that are used with the STARPOINT the working load limit should be reduced accordingly:

|               |              |                |
|---------------|--------------|----------------|
| -10° to 100°C | no reduction | 14°F to 212°F  |
| 100° to 200°C | minus 15%    | 212°F to 392°F |
| 200° to 250°C | minus 20%    | 392°F to 482°F |
| 250° to 350°C | minus 25%    | 482°F to 662°F |

Temperatures above 350°C (662°F) are not permitted.

13. RUD lifting points must not be used under chemical influences such as acids, alkaline solutions and vapours e.g. in pickling baths or hot dip galvanising plants. If this cannot be avoided, please contact the manufacturer indicating the concentration, period of penetration and temperature of use.

14. The position where the lifting points should be attached should be clearly marked with colour.

15. After fitting, an annual inspection or sooner if conditions dictate should be under taken by a competent person examining the continued suitability. Also inspect after damage and special occurrences.

## User Instructions - Part 3

### Inspection criteria concerning paragraphs 2 and 15:

- Ensure compatibility of bolt thread and tapped hole.
- The lifting point should be complete.
- The working load limit and manufacturers stamp should be clearly visible.
- Deformation of the component parts such as body and bolt.
- Mechanical damage, such as notches, particularly in high stress areas.
- Wear should be no more than 10% of cross sectional diameter.
- Evidence of corrosion.
- Evidence of cracks.
- Damage to the bolt and/or thread.
- The body of the STARPOINT must be free to rotate.

**Any non-adherence to this advice may result damages of persons and / or materials!**

| WORKING LOAD LIMITS (G - in tonnes) |            |            |  |      |      |
|-------------------------------------|------------|------------|--|------|------|
| PRODUCT DESCRIPTION                 | Single Leg | Single Leg | 2, 3 or 4 Legs                                       |      |      |
|                                     |            |            | <br>60° 90° 120°<br>Maximum Included Angle (Degrees) |      |      |
| VRS-F M6                            | 0.5        | 0.10       | 0.17   | 0.14 | 0.10 |
| VRS-F M8                            | 1.0        | 0.30       | 0.69   | 0.56 | 0.40 |
| VRS-F M10                           | 1.0        | 0.40       | 0.69   | 0.56 | 0.40 |
| VRS-F M12                           | 2.0        | 0.75       | 1.4  | 1.0  | 0.80 |
| VRS-F M16                           | 4.0        | 1.5        | 2.6  | 2.1  | 1.5  |
| VRS-F M20                           | 6.0        | 2.3        | 4.0  | 3.2  | 2.3  |
| VRS-F M24                           | 8.0        | 3.2        | 5.5  | 4.5  | 3.2  |
| VRS-F M30                           | 12.0       | 4.5        | 7.8  | 6.3  | 4.5  |
| VRS-F M36                           | 16.0       | 7.0        | 12.1   | 9.8  | 7.0  |
| VRS-F M42                           | 24.0       | 9.0        | 15.6   | 12.6 | 9.0  |
| VRS-F M48                           | 32.0       | 12.0       | 20.8   | 16.8 | 12.0 |

Table 1

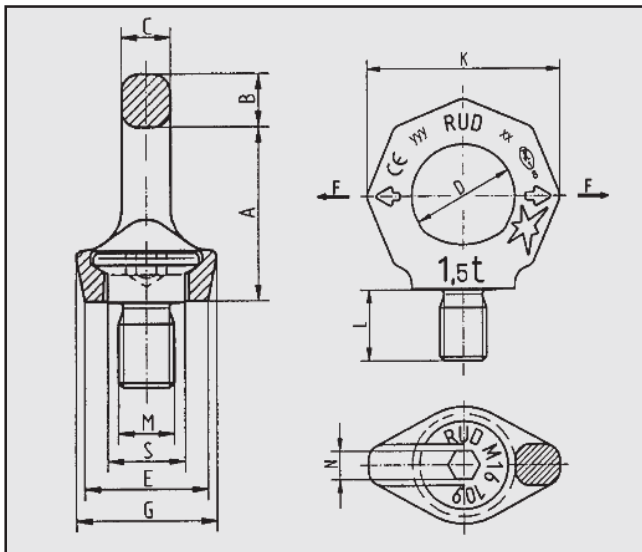

| Type    | WLL (t) | Weight (kg) | A   | B  | C   | D  | E   | G   | K   | L  | M  | N  | S    | Ref.-No. VRS | Ref.-No. VRS-F |
|---------|---------|-------------|-----|----|-----|----|-----|-----|-----|----|----|----|------|--------------|----------------|
| VRS-M6  | 0.1     | 0.06        | 27  | 9  | 7   | 20 | 23  | 28  | 37  | 9  | 6  | 6  | 13   | 7900909      | 7900906        |
| VRS-M8  | 0.3     | 0.1         | 34  | 11 | 8.5 | 25 | 25  | 28  | 47  | 12 | 8  | 6  | 16   | 7100554      | 8500911        |
| VRS-M10 | 0.4     | 0.1         | 34  | 11 | 8.5 | 25 | 25  | 28  | 47  | 15 | 10 | 6  | 15   | 7982219*     | 7104029        |
| VRS-M12 | 0.75    | 0.2         | 42  | 13 | 10  | 30 | 30  | 34  | 56  | 18 | 12 | 8  | 18   | 7982220*     | 7101313        |
| VRS-M16 | 1.5     | 0.3         | 49  | 15 | 14  | 35 | 35  | 40  | 65  | 24 | 16 | 10 | 22   | 7982221**    | 7101314        |
| VRS-M20 | 2.3     | 0.5         | 57  | 17 | 16  | 40 | 40  | 50  | 75  | 30 | 20 | 12 | 27.5 | 7982222**    | 7101315        |
| VRS-M24 | 3.2     | 0.9         | 69  | 21 | 19  | 48 | 48  | 60  | 90  | 36 | 24 | 14 | 33   | 7982223**    | 7101316        |
| VRS-M30 | 4.5     | 1.7         | 86  | 26 | 24  | 60 | 60  | 75  | 112 | 45 | 30 | 17 | 41.5 | 7982224***   | 7101317        |
| VRS-M36 | 7       | 2.9         | 103 | 32 | 29  | 72 | 75  | 90  | 135 | 54 | 36 | 22 | 49.5 | 7984198      | 7984201        |
| VRS-M42 | 9       | 4.6         | 120 | 38 | 34  | 82 | 85  | 105 | 158 | 63 | 42 | 24 | 58   | 7984199      | 7984202        |
| VRS-M48 | 12      | 7.0         | 137 | 43 | 38  | 94 | 100 | 120 | 180 | 72 | 48 | 27 | 66   | 7984200      | 7984203        |

Table 2

\* = packing unit consisting of 20 pieces · \*\* = packing unit consisting of 10 pieces · \*\*\* = packing unit consisting of 4 pieces

## User Instructions - Part 3

| Type            | WLL (t) | Weight (kg) | A   | B  | C   | D  | E   | G   | K   | L  | M      | N      | S    | Ref.-No. VRS | Ref.-No. VRS-F |
|-----------------|---------|-------------|-----|----|-----|----|-----|-----|-----|----|--------|--------|------|--------------|----------------|
| VRS-3/8"-16UNC  | 0.4     | 0.1         | 34  | 11 | 8.5 | 25 | 25  | 28  | 47  | 15 | 3/8"   | 1/4"   | 15   | 7103959      | 7104480        |
| VRS-1/2"-13UNC  | 0.75    | 0.2         | 42  | 13 | 10  | 30 | 30  | 34  | 56  | 18 | 1/2"   | 5/16"  | 18   | 7103960      | 7104481        |
| VRS-5/8"-11UNC  | 1.5     | 0.3         | 49  | 15 | 14  | 35 | 35  | 40  | 65  | 24 | 5/8"   | 3/8"   | 22   | 7103961      | 7104482        |
| VRS-3/4"-10UNC  | 2.3     | 0.5         | 57  | 17 | 16  | 40 | 40  | 50  | 75  | 30 | 3/4"   | 1/2"   | 27.5 | 7103962      | 7104483        |
| VRS-7/8"-9UNC   | 2.3     | 0.6         | 57  | 17 | 16  | 40 | 40  | 50  | 75  | 32 | 7/8"   | 1/2"   | 27.5 | 7103963      | 7104484        |
| VRS-1"-8UNC     | 3.2     | 0.9         | 69  | 21 | 19  | 48 | 48  | 60  | 90  | 36 | 1"     | 9/16"  | 33   | 7103964      | 7104485        |
| VRS-1 1/4"-7UNC | 4.5     | 1.7         | 86  | 26 | 24  | 60 | 60  | 75  | 112 | 45 | 1 1/4" | 5/8"   | 41.5 | 7103965      | 7104486        |
| VRS-1 1/2"-6UNC | 7       | 2.9         | 103 | 32 | 29  | 72 | 75  | 90  | 135 | 54 | 1 1/2" | 7/8"   | 49.5 | 7103966      | 7984221        |
| VRS-1 3/4"-5UNC | 9       | 4.6         | 120 | 38 | 34  | 82 | 85  | 105 | 158 | 63 | 1 3/4" | 1"     | 58   | 7103967      | 7104488        |
| VRS-2"-4.5UNC   | 12      | 7.0         | 137 | 43 | 38  | 94 | 100 | 120 | 180 | 72 | 2"     | 1 1/8" | 66   | 7103968      | 7984223        |

**Table 3**

\* = packing unit consisting of 20 pieces · \*\* = packing unit consisting of 10 pieces · \*\*\* = packing unit consisting of 4 pieces